

"I Love it When a Plan Comes Together"



Display's



Way



Who am I

- Mark Zembruski - "Zman" on all Christmas Forums
 - My one claim to fame in our community that most do not know:
 - I originated the tag line. "I have the **C.L.A.P.**, do you?"
 - Christmas **L**ight **A**ddiction **P**rogram
 - One of the central organizers of **C.L.A.P.** in the PacNW, regional decorating gathering
 - Christmas **L**ight **A**ddiction **P**rogram, for those with **C.L.A.P.**!
 - Christmas Expo Steering and Education committees
 - Yeah OK so what.....
 - Decorating since I was 20
 - Self admitted gadget geek, weekend warrior, learner of all trades, mastering NONE of them.....
 - Decided to start growing Woodinville Wonderland in 2003
 - Approx **125,000** Lights (98% LED)
 - Approx **530+** channels of AC Light Animation
 - **9600** Channels of **RGB** Pixel Animation - 47 E1.31 Universes
 - One traditional DMX Universe
 - Generally I do nothing "original" in my display, I enhance what I steal, er, borrow.....



What's got to do with a Christmas Display?!

Hannibal reveled in success,..... and after all the mayhem turned out so well,.... Rejoiced! "I love it when a plan comes together!!..... However...



What's got to do with a Christmas Display?!

It was **Mr. T** that had a LOT to Say.....

"Everything started as a *Dream*. You gotta have *Insight*, know what you want. You gotta have a *Plan*. Like I tell everybody, if you fail to plan, you're planning to fail. I've been planning ever since I was a youngsta. You've gotta *Start from Somewhere*.....

[Google it.....](#)



I think we listen to **Mr. T...**



I pity the Foo'...! Who don't



Mr. T says.....

- Dreaming
- Insight
- Planning
- Getting started
- Cellar and the Attic...!?... What??

Mr. T also wants you to pay
attention to the
Golden Nuggets of Knowledge





Dreaming:

A Dream doesn't become reality through Magic; it takes sweat determination and hard work

Colin Powell



Dreaming

- Doing a Display is a slippery slope, however, when you close your eyes, what does your minds eye see?
- Big/Small
 - Consequences to each
- Theme / Message / Color Scheme / Technology
 - What influences drive this?



Dreaming

- Why do you want to do it
 - *What's your motivation*
 - May play into how LONG you will do this
- Static or Animation !?
 - Static = Traditional starting point
 - Props, LIGHTS! Gadgets and Gizmos
 - Animation = Dancing Lights!
 - Show/Choreographed Playbill....
 - What type of music?
- Incandescent, LED, RGB?
 - Do you understand the pros/cons?



Dreaming



- What Display features do you see yourself using?
 - Do you know what's out there to use?
 - How are you going to acquire them?
 - How will you incorporate them?
- DIY or Off the Shelf? What's the difference?
- Artistic approach or **MAJOR WOW!**
 - Amalgamate vignettes (Traditional)
 - Techno, Pixel (Modern)
 - Blend of both?





Planning:
*A Dream without a Plan
is just a wish...*

Antoine de Saint-Exupéry



Planning

- The first 3 habits from Stephen R Covey play a key role to the success of your Display
- **Be Proactive**
 - Take initiative in your Display by realizing that your decisions (and how they align with your own principles) are the primary determining factor in the realization of your Display.
- **Begin with the end in mind**
 - Self-discover and clarify your own character values and Display goals. Envision the ideal characteristics for each of your various goals and then the inter-dependencies in Display.
- **Put first things first**
 - Plan, prioritize, and execute your tasks based on importance rather than urgency. Order of Operation



Planning

- Soooooo,....Do not take this lightly
- Do you have the following....
 - Does not have to be fancy
 - Paper or Electronic
 - Display Plan
 - Electrical Plan
 - Communications Plan
 - Notes
 - Punch & To- Do Lists - Reference Info



Planning - Yard Layout

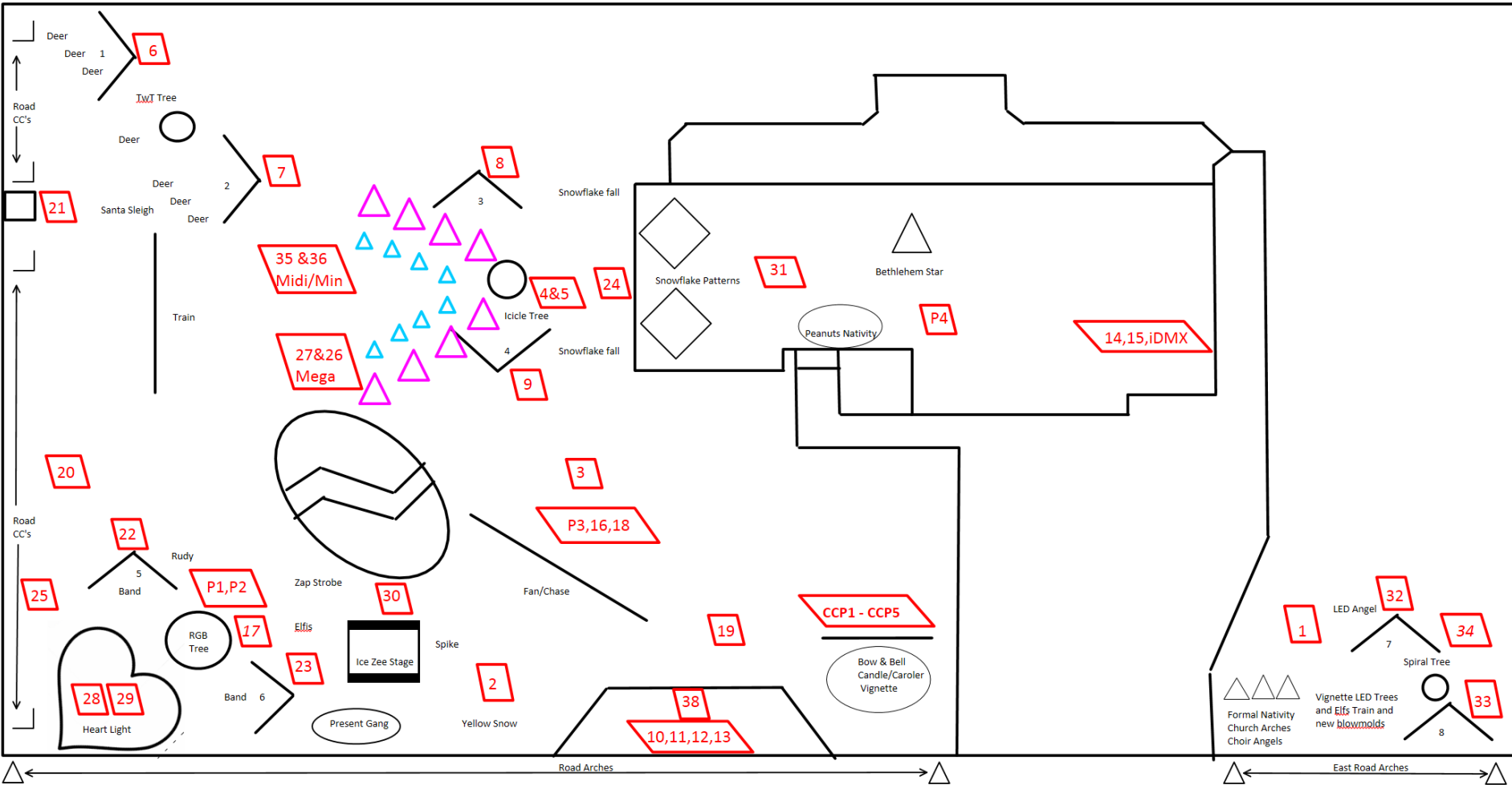

Planning - Electrical



Bulb/Light List	WATTS / Amps	Power Type	Item Type	Bulbs per string	Volts AC/ID C	Watts per Bulb	Watts per string	AMPS per light	AMPS per String	Feet Per String
Inflatable Igloo	52.0000	WATTS	Unit	1	120	52.0 Watts	52 Watts	.4333 Amps	0.433	
Inflatable Santa	80.0000	WATTS	Unit	1	120	80.0 Watts	80 Watts	.6667 Amps	0.667	
Flash House	0.7300	AMPS	String	240	120	.395 Watts	35 Watts	.0033 Amps	0.730	
Flash Sit	0.7500	AMPS	String	250	120	.36 Watts	30 Watts	.003 Amps	0.750	
Flash Fan	0.7500	AMPS	String	250	120	.36 Watts	30 Watts	.003 Amps	0.750	
Chauret 200Bs	0.2300	AMPS	Unit	1	120	27.6 Watts	28 Watts	.23 Amps	0.230	
Roof SnooFakes LED Rope	0.0300	AMPS	Unit	1	120	10.8 Watts	11 Watts	.03 Amps	0.030	
Flood - Small Costco LED	0.0500	AMPS	Bulb	1	120	6.0 Watts	6 Watts	.05 Amps	0.050	
Flood - Large Costco LED	0.0300	AMPS	Bulb	1	120	10.8 Watts	11 Watts	.03 Amps	0.030	
M6 CDI LED 100	0.0600	AMPS	String	100	120	.072 Watts	7 Watts	.0006 Amps	0.060	34
Candy Cane Wire Frame	0.5800	AMPS	String	150	120	.464 Watts	70 Watts	.0033 Amps	0.580	
M5 HL Replaceable LED		AMPS		50	120	FALSE	FALSE	FALSE	FALSE	17
C6 CDI LED 100	0.0600	AMPS	String	100	120	.072 Watts	7 Watts	.0006 Amps	0.060	34

Spreadsheet to manage light inventory and power consumption

Warning Threshold (Vallau) 35%

Controller 1-25 Overview

Controller Location	Model	VOLTS	AMPS	1	2	3	4	5	6	7	8	9	10	11	12	13	14	15	16	Controller Totals			
Amps	Bulbs	Watts																					
Controller 1	Wash Coat / Blown Tree	CTB14D.1	120	15	0.01	0.01	0.01	0.50				1.34				0.84	0.75	0.54	0.34		4.391	4710	526.95
Controller 2	Flash	CTB14D.2	120	15	0.06	0.79	0.75	0.01	0.75	0.01	0.75	0.01	0.75	0.01	0.75	0.01	0.06	0.05	0.20	0.20	5.172	2815	620.54
Controller 3	Front Yard / Mini Tree	CTB14D.3	120	15		0.60		0.57		0.51	0.07	2.20			0.32	0.28	0.08	0.08	0.08		4.978	8194	597.35
Controller 4		CTB14D.4	120	15	0.03	0.03	0.03	0.03	0.03	0.03	0.03	0.03	0.03	0.05	0.05	0.05	0.05	0.05	0.05	0.05	6.600	1680	72
Controller 5		CTB14D.5	120	15	0.08	0.08	0.08	0.08	0.08	0.08	0.08	0.08	0.10	0.10	0.10	0.10	0.10	0.10	0.10	1.400	2920	165	
Controller 6	LLA1	CTB14D.6	120	15	0.02	0.02	0.02	0.02	0.02	0.02	0.02	0.02	0.02	0.02	0.02	0.02	0.02	0.02	0.08	1.01	1.382	1950	165.8
Controller 7	LLA2	CTB14D.7	120	15	0.02	0.02	0.02	0.02	0.02	0.02	0.02	0.02	0.02	0.02	0.02	0.02	0.02	0.02	1.34	1.41	2.042	2030	265.8
Controller 8	LLA3	CTB14D.8	120	15	0.02	0.02	0.02	0.02	0.02	0.02	0.02	0.02	0.02	0.02	0.02	0.02	0.02	0.02			0.292	1400	35
Controller 9	LLA3	CTB14D.9	120	15	0.02	0.02	0.02	0.02	0.02	0.02	0.02	0.02	0.02	0.02	0.02	0.02	0.02	0.02			0.292	1400	35
Controller 10	Road Arches	CTB14D.10	120	15	0.02	0.02	0.02	0.02	0.02	0.02	0.02	0.02	0.02	0.02	0.02	0.02	0.02	0.02	0.02	0.02	0.333	1600	40
Controller 11	Road Arches	CTB14D.11	120	15	0.02	0.02	0.02	0.02	0.02	0.02	0.02	0.02	0.02	0.02	0.02	0.02	0.02	0.02	0.02	0.02	0.313	1600	40
Controller 12	Road Arches	CTB14D.12	120	15	0.02	0.02	0.02	0.02	0.02	0.02	0.02	0.02	0.02	0.02	0.02	0.02	0.02	0.02	0.02	0.02	0.333	1600	40
Controller 13	Road Arches	CTB14D.13	120	15	0.02	0.02	0.02	0.02	0.02	0.02	0.02	0.02	0.02	0.02	0.02	0.02	0.02	0.02	0.02	0.02	0.333	1600	40
Controller 14	Roof / Eave	CTB14D.14	120	15	0.90	0.08	2.70	0.12	0.58	0.58	0.21	0.21	0.21	0.21	0.28		0.02	0.02	0.10		6.214	3895	745.7
Controller 15	Roof / Eave	CTB14D.15	120	15	7.65	0.05	0.07	0.25	0.09	0.08	0.08	0.08	0.08	0.04	0.02	0.02	0.30	0.02	0.02	0.02	9.383	4969	1127.25
Controller 16	Light Fan	CTB14D.16	120	15	0.02	0.02	0.02	0.02	0.02	0.02	0.02	0.02	0.02	0.02	0.02	0.02	0.02	0.02			0.313	1500	37.5
Controller 17	Road / Pine Road	CTB14D.17	120	15	0.05	0.01	0.01	0.01	0.07	0.15	0.15	0.02	0.02	0.01	0.01	0.01	0.01	0.15	0.15	0.05	0.891	1492	106.95
Controller 18	Chase Trees 1-16	CTB14D.18	120	15	0.05	0.05	0.05	0.05	0.05	0.05	0.05	0.05	0.05	0.05	0.05	0.05	0.05	0.05	0.05	0.833	4000	100	
Controller 19	Front Yard / Blown Trees	CTB14D.19	120	15		0.52	0.43	1.47		0.03	3.46	0.12	0.28	0.10	0.03	0.10	0.08	0.10	0.08	0.45	7.293	9191	782.904
Controller 20	Road Candy Canes	CTB14D.20	120	15	0.12	0.12	0.12	0.12	0.12	0.12	0.12	0.12	0.12	0.12	0.12	0.12	0.12	0.12	0.12	1.920	3200	230.4	
Controller 21	Road Candy Canes	CTB14D.21	120	15	0.12	0.12	0.12	0.12	0.12	0.12	0.12	0.12	0.12	0.12	0.12	0.12	0.12	0.12	0.12	1.920	3200	230.4	
Controller 22	LLA5	CTB14D.22	120	15	0.02	0.02	0.02	0.02	0.02	0.02	0.02	0.02	0.02	0.02	0.02	0.02	0.02	0.02	0.02	0.25	0.292	1400	35
Controller 23	LLA5	CTB14D.23	120	15	0.02	0.02	0.02	0.02	0.02	0.02	0.02	0.02	0.02	0.02	0.02	0.02	0.02	0.02	0.02	0.25	0.542	1405	65
Controller 24	Snowflake Fall	CTB14D.24	120	15	0.09	0.09	0.09	0.09	0.09	0.09	0.09	0.09	0.09	0.09	0.09	0.09	0.09	0.09	0.09	0.09	1.440	16	172.8
Controller 25	Mini Snowflake Display	CTB14D.25	120	15										0.02	0.02	0.02	0.02	0.06	0.01	0.01	0.199	900	22.5

Copyright © 2019 Woodville Wonderland

Display Totals 54.088 69667 6403.1



Planning - Electrical



NOT ONLY WILL THIS
KILL YOU, IT WILL HURT
THE WHOLE TIME
YOU ARE DYING

- **BE SAFE!!!**
- You will need to get comfortable with AC & DC
- How will you access power outside
 - Extension cords
 - In Yard or Central location
 - Temporary sub panels
 - **DO NOT OVER LOAD YOUR POWER GRID!**

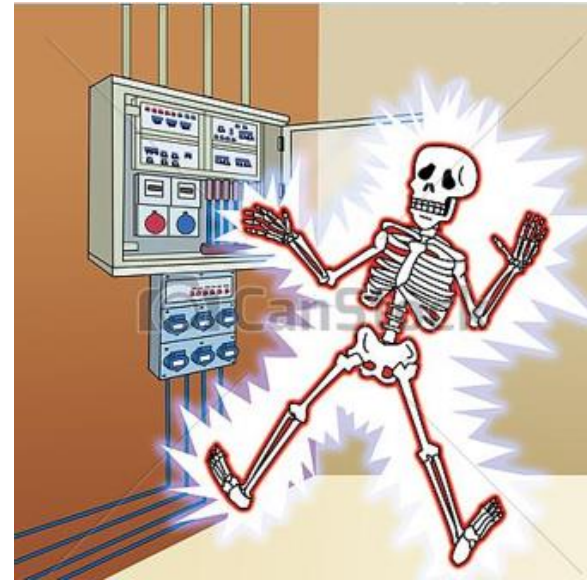

Planning - Electrical

- Know, and Pay attention to wire capacity
- Use your Spread sheet for every element you use!
- GFCI's vs AFCI's?
 - Protect you, guests, family, pets and equipment
 - Buy quality, less issues
 - Understand how to effectively use them



NOT ONLY WILL THIS
KILL YOU, IT WILL HURT
THE WHOLE TIME
YOU ARE DYING

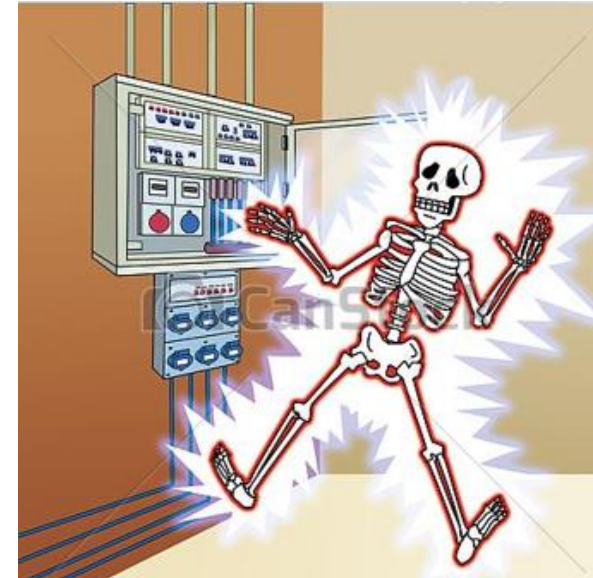

Planning - OneNote Notebook



Christmas ▾ Christmas Planning Christmas Notes Christmas Web Sites Christmas Idea Info LOR Notes DMX RGB Electronics Blow Molds PacNW Regional CLAP Expo + Search (Ctrl+E)

★ To - Do's / Notes

Monday, March 10, 2008 9:05 PM

Potential Sequence Song List

1. Auld Lang Sine for New Years show
2. Wonderland Christmas - Boston Pops - Festival Mix - See video
3. Wonderland Christmas - Disco Santa - See video
4. TSO - An Angel Returned
5. Boggy Helms - Jingle Bell Rock
6. Xmas Party - Rockin Little Christmas Tree
7. Faith Hill - Where are you Christmas - Pre Sequence in Directory
8. Beach Boys - Little St Nick
9. Mannheim Steamroller - Sleigh Ride
10. TSO - Appalachian Snowfall
11. Christmas Vacation
12. Bing Crosby Jingle Bells (Swing arrangement)
13. Reflections on Earth
14. Disney Angel
15. Spiraling - Do you hear what I hear - <http://www.vimeo.com/18222650>
Sequence downloaded to Staging.

General/Thoughts/Fix-It items

1. New Merry Christmas Sign?
2. Make either firework/star sticks in place of Snowflake fall
3. New red Bows to replace bow/bell, candle and make same as CC's on Bedroom window
4. Star w/in Star wireframe
5. Ferris Wheel
6. Add smaller arches under LLAs.
7. Snowflakes on roof, 3' spacing good.

RGB Tree Pixel Info:

1. <http://www.aliexpress.com/fm-store/701799/209889132-521371851/RGB-full-LED-pixel-module-WS-2801-IC-DC5V-input-50pcs-a-string.html> - From Ray Wu's site.
2. 2801 CCR - <http://www.aliexpress.com/fm-store/701799/209843764-465132154/5m-led-digital-strip-DC5V-input-WS2801IC-256-scale-32pcs-IC-and-32pcs-5050-SMD-RGB.html>

LONG TERM Consideration

1. Video
 - a. Get with Mike Z to discuss
2. Cover roof pitches with lights and net to simulate snow like Disney Castle and Darren/I discussed

Notes During Set up

1. House C9's make sure you offset the first bulb on corner of house by gas meter. Do not tie socket to screw post.
2. 10 North poles on each side of Driveway. 5.5' spacing on west 6' on east
3. RGB Balls in Mega. Make 2 sides higher than middle for top most balls.

What to re-think

1. Light "North Pole" sign on North Pole
2. Island flood wash
3. Smaller bulbs in BM's
4. RGB Matrix on Porch Posts

<http://www.frostking.com/electric-roof-cable-kits/>
Heat Cable...

133K
ANTI-SEIZE
LUBRICANT
NET WT. 8 FL. OZ. (CONT. 236 ml)

Pasted from
<<http://forums.planetchristmas.com/index.php?topic/51115-galvanized-or-black/>>

To - Do's / Notes

- Display Misc - Fixit - Wish
- DMX - Pixel Plan
- Yard Plan 2010
- Yard Plan 2011
- Yard Plan 2012
- Yard Plan 2013
- Yard Plan 2014
- Yard Plan 2015
- Yard Plan 2016
- Yard Plan 2017



Planning - Communications



DMX - Pixel Plan

Wednesday, March 12, 2008 9:45 PM

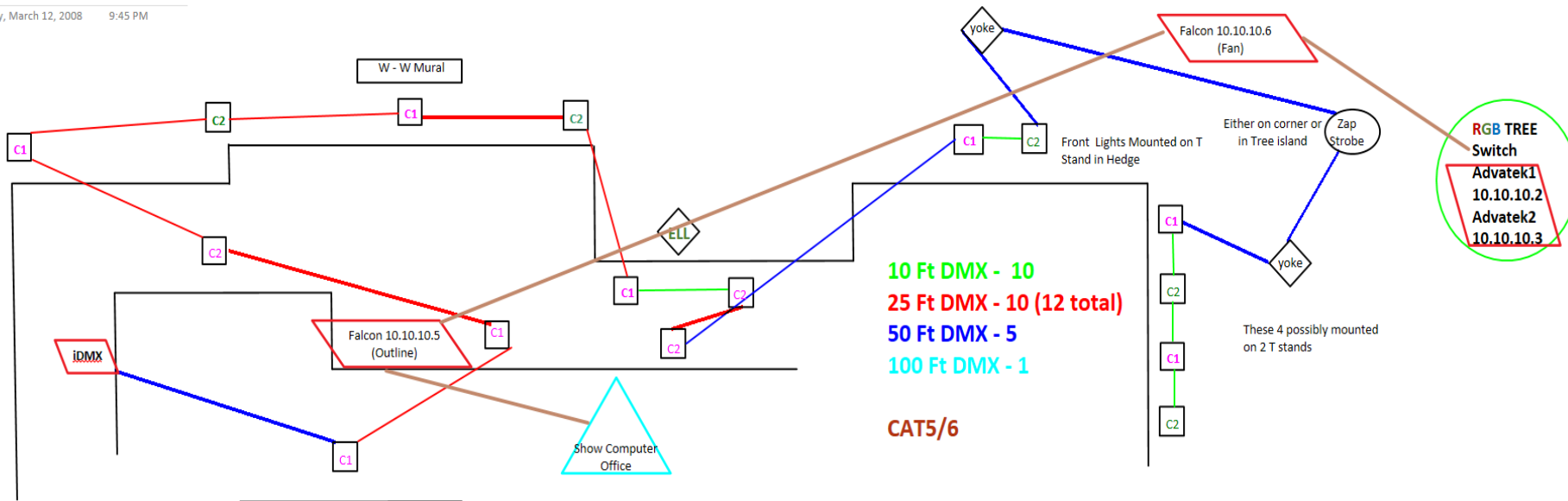

- DMX
 - Fixtures and Cabling
- E1.31
 - Switches & Controllers
- Wireless
 - Transmitter and Receivers
- Cat5/6



Planning

Doing a Display, you **WILL** spend a **LOT** of **TIME**, you don't **HAVE** to spend lot of **MONEY**....

- **BUDGET**
- What is your biggest **SPEND** doing a display?

- Time

- Becomes the major budget in long term
- Save stress, double your time allotment for **EVERYTHING**

- Money

- What are you comfortable spending
- Research for frugal purchases or more **DIY**
- Never spend all your budget, keep some in reserve for **Set Up!**



Planning

- Logistics?
 - **What** will you store things in....
 - **Where** will you store things
 - Ensure you are organized and know where things are at in storage (inventory list)
- Security?
 - Your Display, your family and your guests
- Charity?
 - Is this something you desire to do
 - Collaborate and communicate with your Charity
 - Is this advertised



Planning



- Publicity
 - Website
 - Facebook page
 - Local Publications
 - Newspapers, Radio or TV
 - **UNDERSTAND HOW DOING THIS WILL IMPACT YOU, YOUR FAMILY, NEIGHBORHOOD!**
- Neighbor Relations
 - Impact to your area
 - HOA consideration?
- Devise a Plan and **STICK TO IT!**
 - Resist those "On man, I gotta add that..." urges
 - Less stress
 - Start planning for next year **NOW!...**
 - Capture notes, What worked/didn't, New Additions, Fix It etc.... (OneNote) Guest input





Insight:

When you change the way
you look at things, the
things you look at
change.....

Wayne Dyer



Insight

- Where do you go for...
 - Information?
 - Ideas?
 - Help?
 - Forum Pages
 - FaceBook Pages - Too many to post!
 - Instructors caution, wear leather chaps....
- Get plugged into your local decorating community
 - Light up Ohio, ACDC, PacNW C.L.A.P., EPIC..... to name just a few....
 -  **Christmas Expo** at local level (Mini)
 - Find a buddy/mentor (or become one!)



Insight - Visit by clicking logo



Light-O-Rama Forums



Insight

- How do you look at your display?
 - Do you see your Display as lights and elements or as a Composition?
 - Do you see your Display the same way your visitors do? Does this matter to you?
 - Do you spend time outside visiting during the Season and interacting with your visitors
 - Do you get input from family, friends?
- Its not **WHAT** you have, its what you **DO**... with what you have....
 - Are you unique? or just a me too....



Insight



- Consider adding an umbrella policy on your homeowners policy
- Crawl - Walk - Run!!!
 - Cannot be stressed enough
 - Ensure balance in life - work - family - Christmas
 - Remember its Christmas!





Getting Started:

If you have a *Dream*,
you can spend a lifetime
Studying and Planning,
getting ready. What you
DO should have meaning
and purpose. *Get
Started* by taking that
first step...

Drew Houston



Getting Started



- Keeping in mind the "B" word.... Budget... as the clock is ticking...
- When do you "Start" ...?
 - Building/acquiring new elements....
 - Fix its.....
 - Programming if you animate...
 - Setting things up, Thanksgiving !!?
 - Do you know/understand your logistics?
 - Weather, Leaves? Lawn growth? HOA Rules, Etc...
- Organize your approach
 - **USE** your plan documents
 - First things first... "Order of Operation"



Getting Started

- **Make your connection cords**

- SPT1 or SPT2 "Lamp Cord"
- Vampire plugs and sockets
- Both same amperage (7amps), just a bit thinner insulation
- Socket or "Channel" connection cords
- Customized Harnesses
- Saves space and weight in storage!
- Standardize on one and keep an inventory on hand
- NOTE: SPT2 is compatible with store bought cords



- **Color coding Power & Communications**

- Switched for static grid **(Blue)**
- 24x7 for equip **(Red)**
- Buy good quality 14-3 cords or better
- AC Network **(Green)** - DC Network **(Black)**



Getting Started



- Power connections off the ground
 - Stakes, boards, rocks, bricks etc..
 - **DO NOT WRAP** your plugs!
- Tweak your layout considering visitor viewing lines/angles, layering elements
- Consider assembling a portable toolkit and carry it at all times
 - Zip ties, nippers, small pliers, wire stripper screwdrivers, butane soldering iron
- Tap into family, friends, neighbors, volunteers early on for help
 - Schools for Community Service Hours





Cellar and the Attic:

All the real eclectic stuff
in life ends up in the Cellar
or the Attic

Mark Zembruski



Cellar and the Attic

- Pre-Season Sales (Jan-April)
 - LEDs, Pixels, Misc...
 - Announced on forums, FB pages and emails from vendors
- Group buys on forums/pages or local mini's
- **Keep spares on hand as much as possible**
 - Elements were possible
 - Lights/Pixels
 - Spare controllers
 - Spare channels
 - Dongles
 - Power supplies
- **Backup your electronic data!**
 - Keep a history of each year
 - Sequencing, back up **ALL THE TIME**



Cellar and the Attic

- Organize all your cords by length



- Cut off the irritating tags on your light strings, and store-bought extension cords
 - It takes time but looks SOOO much better.



Cellar and the Attic

- Get a small jar and save the 3A fuses that come in the irritating plastic blob
- **Recycle your used, dead, burnt-out cords/light strings**
 - Find a local store or organization
 - Save the Male/Female ends off dead light strings as these do fail!
- When using Silicone, be sure to use RTV Silicone or Lexel
- Outdoor vs Indoor
 - So..... What's the difference?
 - Mostly nothing, its all in the Marketing!



Cellar and the Attic



- Keep your eyes open in every store you go into **ALWAYS** with your display in mind....
 - You never know when you see something that can solve a logistic issue



That's a Wrap! Mr. T Says...



- In everything you do, remember... "Once Mr. T is out of the Van, there is no getting him back in".
- Steal ideas for your needs, but never forget where you got it from
 - See how you can put your own twist on it.....
- Do what YOU want to do, and have fun doing it. Remember is Christmas!
- Don't create something, where someone thinks Hannibal, er, ah "Christmas threw up on the lawn!"



That's a Wrap!

Mr. T - Christmas Story



Questions?





Christmas Expo

Thank you for attending!
Mark "Zman" Zembruski
WoodinvilleWonderland.com
modec@frontier.com

